

## LCE N-Channel Enhancement Mode Power MOSFET

### Description

The LCE6003Y uses advanced trench technology to provide excellent  $R_{DS(ON)}$ , low gate charge and operation with gate voltages as low as 2.5V. This device is suitable for use as a Battery protection or in other switching application.

### General Features

- $V_{DS} = 60V, I_D = 3A$   
 $R_{DS(ON)} < 105m\Omega @ V_{GS} = 10V$   
 $R_{DS(ON)} < 125m\Omega @ V_{GS} = 4.5V$
- High power and current handling capability
- Lead free product is acquired
- Surface mount package

### Application

- Battery switch
- DC/DC converter

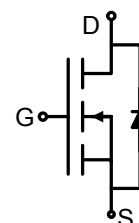

Schematic Diagram

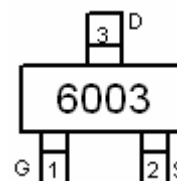

Marking and Pin Assignment

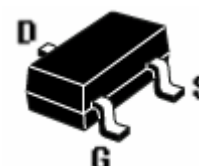

SOT-23 -3L Top View

### Package Marking and Ordering Information

| Device Marking | Device   | Device Package | Reel Size | Tape width | Quantity   |
|----------------|----------|----------------|-----------|------------|------------|
| 6003           | LCE6003Y | SOT-23-3L      | Ø180mm    | 8 mm       | 3000 units |

### Absolute Maximum Ratings ( $T_A = 25^\circ\text{C}$ unless otherwise noted)

| Parameter  | Symbol         | Limit      | Unit             |
|--|----------------|------------|------------------|
| Drain-Source Voltage                             | $V_{DS}$       | 60         | V                |
| Gate-Source Voltage                              | $V_{GS}$       | $\pm 20$   | V                |
| Drain Current-Continuous                         | $I_D$          | 3          | A                |
| Drain Current-Pulsed <sup>(Note 1)</sup>         | $I_{DM}$       | 10         | A                |
| Maximum Power Dissipation                        | $P_D$          | 1.7        | W                |
| Operating Junction and Storage Temperature Range | $T_J, T_{STG}$ | -55 To 150 | $^\circ\text{C}$ |

### Thermal Characteristic

|   |                 |      |                    |
|---|-----------------|------|--------------------|
| Thermal Resistance, Junction-to-Ambient <sup>(Note 2)</sup> | $R_{\theta JA}$ | 73.5 | $^\circ\text{C/W}$ |
|---|-----------------|------|--------------------|

### Electrical Characteristics ( $T_A = 25^\circ\text{C}$ unless otherwise noted)

| Parameter                       | Symbol     | Condition                     | Min | Typ | Max | Unit    |
|---------------------------------|------------|-------------------------------|-----|-----|-----|---------|
| <b>Off Characteristics</b>      |            |                               |     |     |     |         |
| Drain-Source Breakdown Voltage  | $BV_{DSS}$ | $V_{GS} = 0V, I_D = 250\mu A$ | 60  | 65  | -   | V       |
| Zero Gate Voltage Drain Current | $I_{DSS}$  | $V_{DS} = 60V, V_{GS} = 0V$   | -   | -   | 1   | $\mu A$ |



|  |              |   |     |      |           |            |
|--|--------------|---|-----|------|-----------|------------|
| Gate-Body Leakage Current                            | $I_{GSS}$    | $V_{GS}=\pm 20V, V_{DS}=0V$                             | -   | -    | $\pm 100$ | nA         |
| <b>On Characteristics</b> <sup>(Note 3)</sup>        |              |   |     |      |           |            |
| Gate Threshold Voltage                               | $V_{GS(th)}$ | $V_{DS}=V_{GS}, I_D=250\mu A$                           | 1.0 | 1.3  | 2.0       | V          |
| Drain-Source On-State Resistance                     | $R_{DS(ON)}$ | $V_{GS}=10V, I_D=3A$                                    | -   | 78   | 105       | m $\Omega$ |
|  |              | $V_{GS}=4.5V, I_D=3A$                                   | -   | 95   | 125       | m $\Omega$ |
| Forward Transconductance                             | $g_{FS}$     | $V_{DS}=15V, I_D=2A$                                    |     | 3    | -         | S          |
| <b>Dynamic Characteristics</b> <sup>(Note 4)</sup>   |              |   |     |      |           |            |
| Input Capacitance                                    | $C_{ISS}$    | $V_{DS}=30V, V_{GS}=0V,$<br>$F=1.0MHz$                  | -   | 247  | -         | PF         |
| Output Capacitance                                   | $C_{OSS}$    |   | -   | 34   | -         | PF         |
| Reverse Transfer Capacitance                         | $C_{RSS}$    |   | -   | 19.5 | -         | PF         |
| <b>Switching Characteristics</b> <sup>(Note 4)</sup> |              |   |     |      |           |            |
| Turn-on Delay Time                                   | $t_{d(on)}$  | $V_{DD}=30V, I_D=1.5A$<br>$V_{GS}=10V, R_{GEN}=1\Omega$ | -   | 6    | -         | nS         |
| Turn-on Rise Time                                    | $t_r$        |   | -   | 15   | -         | nS         |
| Turn-Off Delay Time                                  | $t_{d(off)}$ |   | -   | 15   | -         | nS         |
| Turn-Off Fall Time                                   | $t_f$        |   | -   | 10   | -         | nS         |
| Total Gate Charge                                    | $Q_g$        | $V_{DS}=30V, I_D=3A,$<br>$V_{GS}=4.5V$                  | -   | 6    | -         | nC         |
| Gate-Source Charge                                   | $Q_{gs}$     |   | -   | 1    | -         | nC         |
| Gate-Drain Charge                                    | $Q_{gd}$     |   | -   | 1.3  | -         | nC         |
| <b>Drain-Source Diode Characteristics</b>            |              |   |     |      |           |            |
| Diode Forward Voltage <sup>(Note 3)</sup>            | $V_{SD}$     | $V_{GS}=0V, I_S=3A$                                     | -   | -    | 1.2       | V          |
| Diode Forward Current <sup>(Note 2)</sup>            | $I_S$        |   | -   | -    | 3         | A          |

**Notes:**

1. Repetitive Rating: Pulse width limited by maximum junction temperature.
2. Surface Mounted on FR4 Board,  $t \leq 10$  sec.
3. Pulse Test: Pulse Width  $\leq 300\mu s$ , Duty Cycle  $\leq 2\%$ .
4. Guaranteed by design, not subject to production

Typical Electrical and Thermal Characteristics

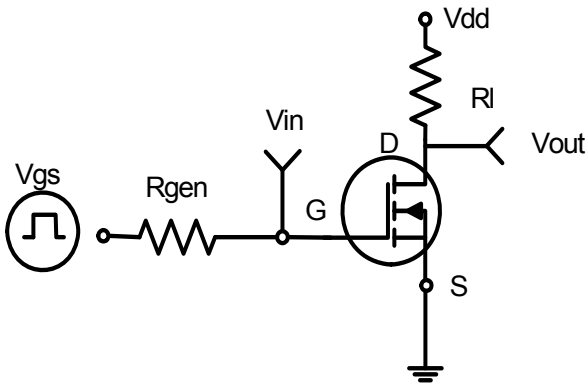

Figure 1: Switching Test Circuit

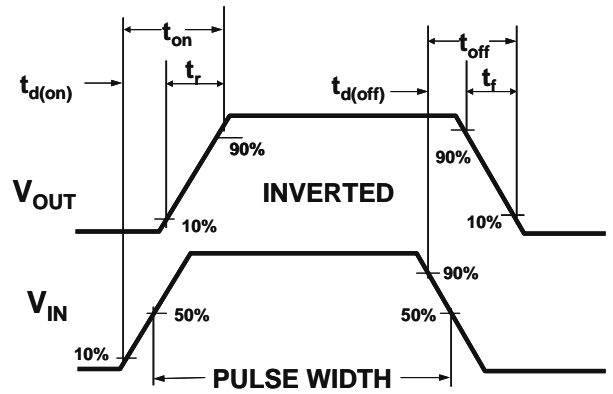

Figure 2: Switching Waveforms

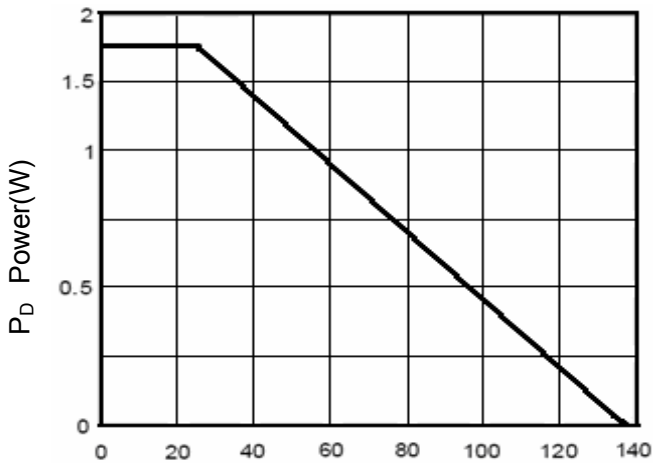

Figure 3 Power Dissipation

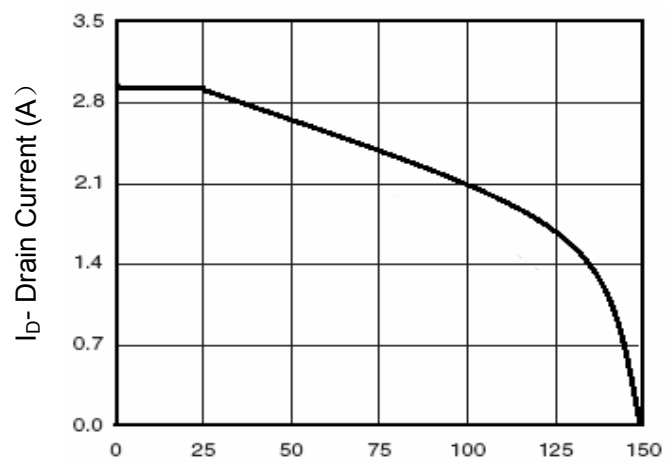

Figure 4 Drain Current

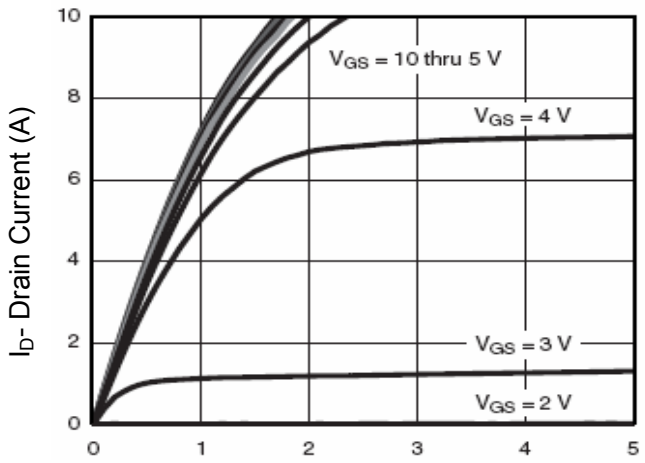

Figure 5 Output Characteristics

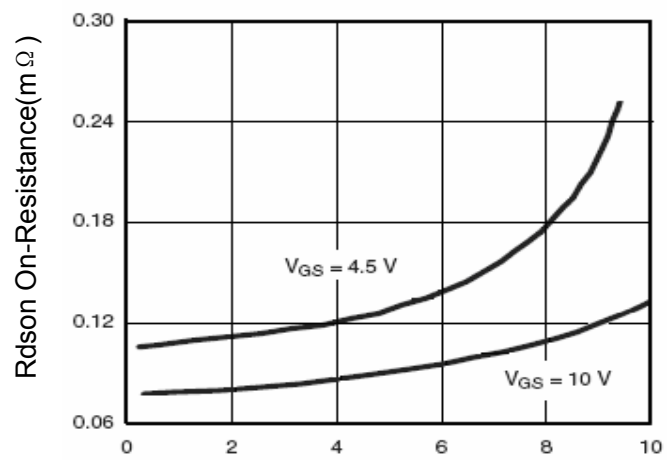
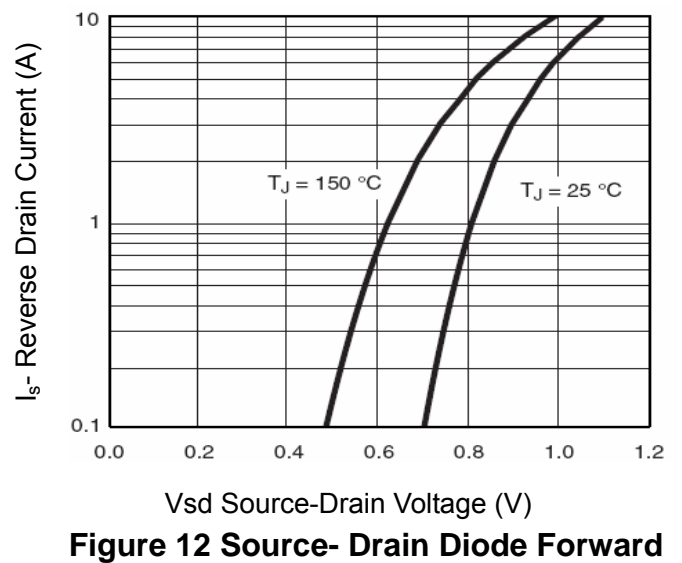
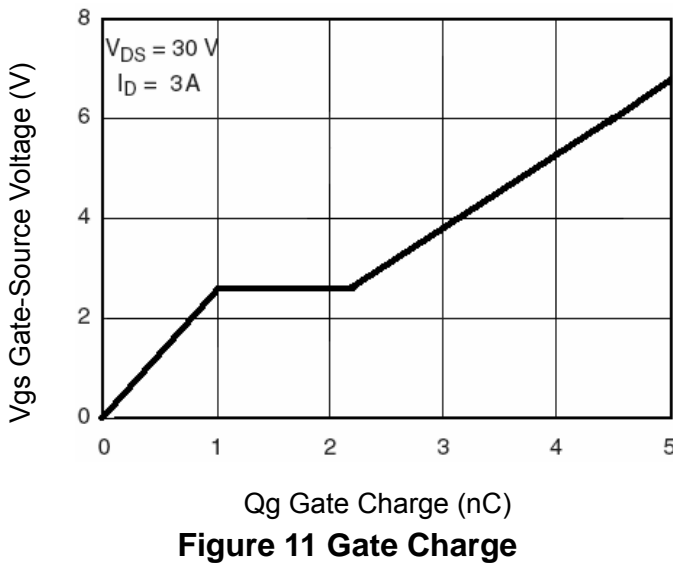
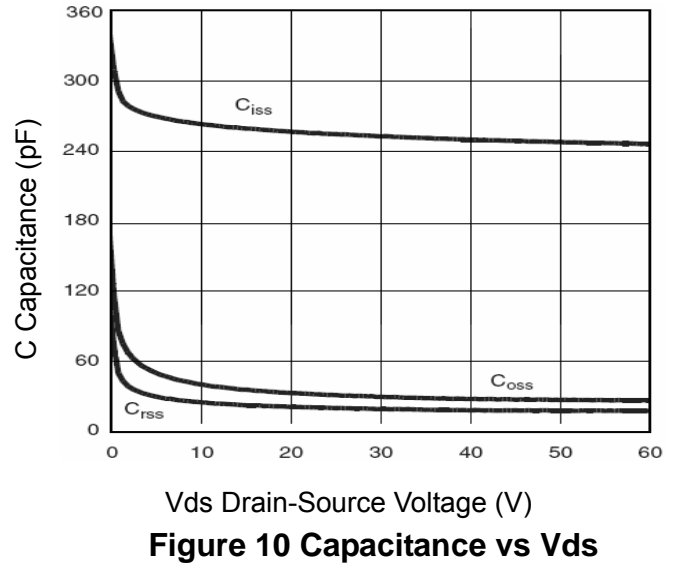
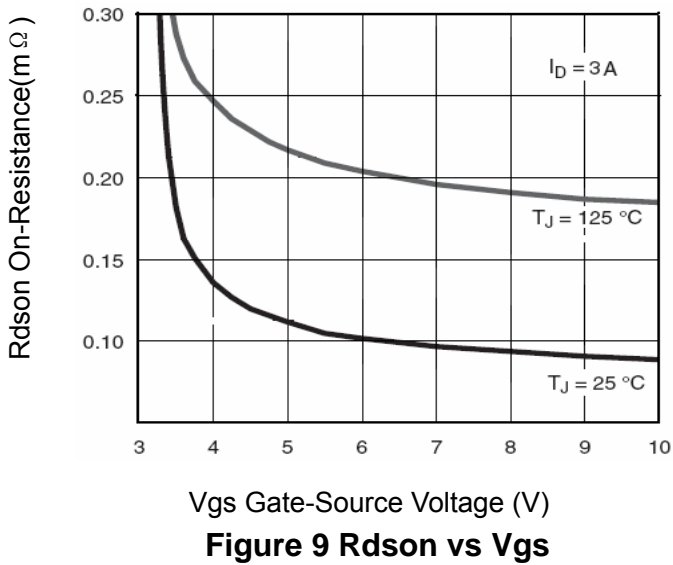
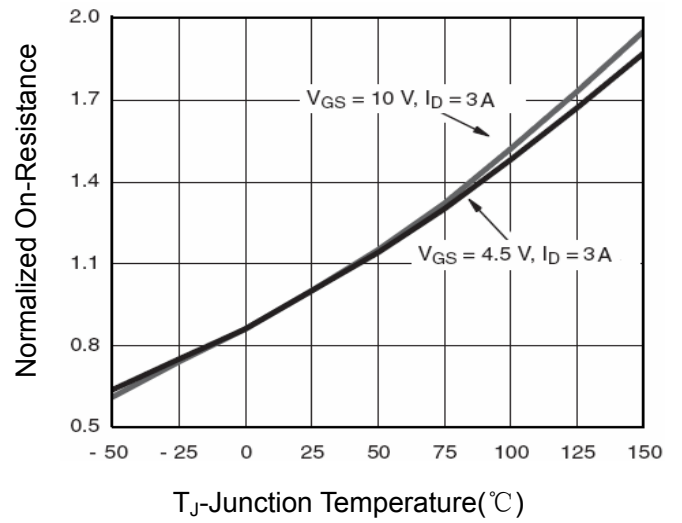
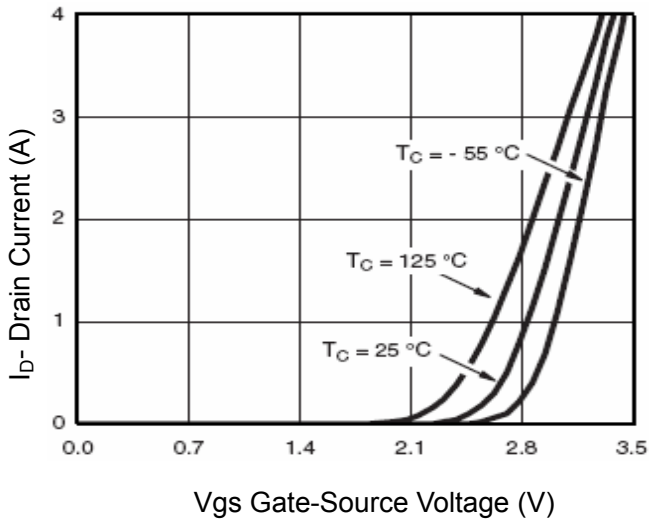
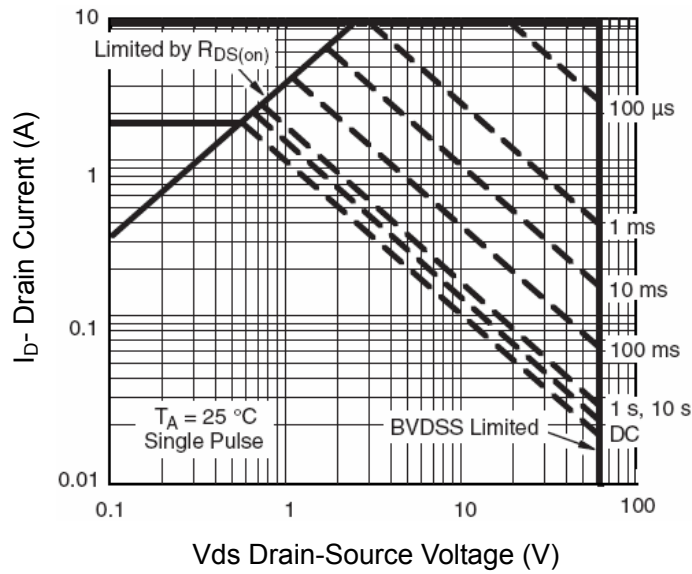
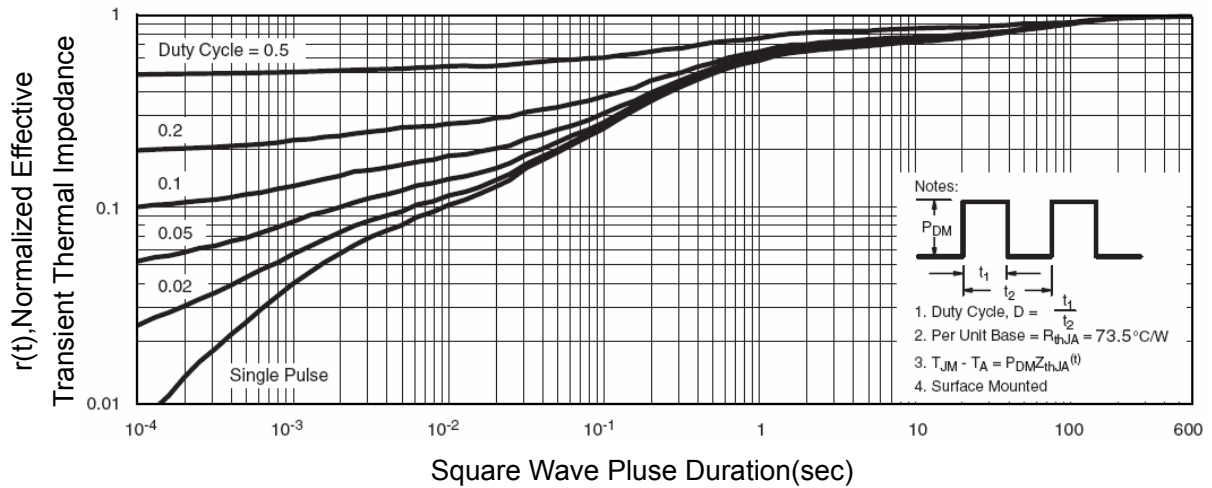

Figure 6 Drain-Source On-Resistance





**Figure 13 Safe Operation Area**



**Figure 14 Normalized Maximum Transient Thermal Impedance**



## SOT-23-3L Package Information

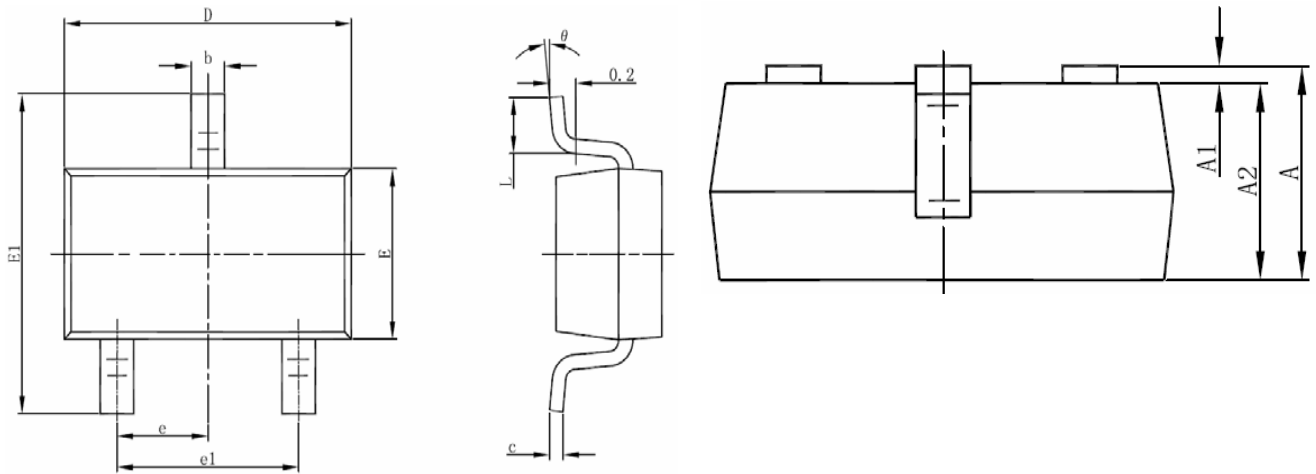

| Symbol   | Dimensions In Millimeters |       | Dimensions In Inches |       |
|----------|---------------------------|-------|----------------------|-------|
|          | Min                       | Max   | Min                  | Max   |
| A        | 1.050                     | 1.250 | 0.041                | 0.049 |
| A1       | 0.000                     | 0.100 | 0.000                | 0.004 |
| A2       | 1.050                     | 1.150 | 0.041                | 0.045 |
| b        | 0.300                     | 0.500 | 0.012                | 0.020 |
| c        | 0.100                     | 0.200 | 0.004                | 0.008 |
| D        | 2.820                     | 3.020 | 0.111                | 0.119 |
| E        | 1.500                     | 1.700 | 0.059                | 0.067 |
| E1       | 2.650                     | 2.950 | 0.104                | 0.116 |
| e        | 0.950(BSC)                |       | 0.037(BSC)           |       |
| e1       | 1.800                     | 2.000 | 0.071                | 0.079 |
| L        | 0.300                     | 0.600 | 0.012                | 0.024 |
| $\theta$ | 0°                        | 8°    | 0°                   | 8°    |

## Notes

- All dimensions are in millimeters.
- Tolerance  $\pm 0.10\text{mm}$  (4 mil) unless otherwise specified
- Package body sizes exclude mold flash and gate burrs. Mold flash at the non-lead sides should be less than 5 mils.
- Dimension L is measured in gauge plane.
- Controlling dimension is millimeter, converted inch dimensions are not necessarily exact.