

Description

The LMAK80N03 uses advanced trench technology to provide excellent $R_{DS(ON)}$, low gate charge and operation with gate voltages as low as 4.5V. This device is suitable for use as a Battery protection or in other Switching application.

Dimensions TO-252

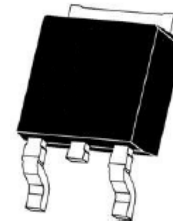

General Features

- $V_{DS} = 30V$ $I_D = 80 A$
- $R_{DS(ON)} < 6m\Omega @ V_{GS}=10V$

Application

- Battery protection
- Load switch
- Uninterruptible power supply

Pin Configuration

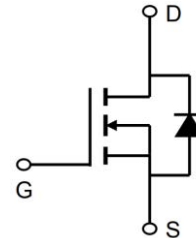

Package Marking and Ordering Information

Device	Device Marking	Device Package	Reel Size	Tape width	Quantity
LMAK80N03	AP80N03D	TO-252	-	-	2500 units

Absolute Maximum Ratings (TC=25°C unless otherwise noted)

Symbol	Parameter	Rating	Units
V_{DS}	Drain-Source Voltage	30	V
V_{GS}	Gate-Source Voltage	± 20	V
I_D	Drain Current – Continuous ($T_C=25^\circ C$)	80	A
	Drain Current – Continuous ($T_C=100^\circ C$)	51	A
I_{DM}	Drain Current – Pulsed ¹	320	A
EAS	Single Pulse Avalanche Energy ²	88	mJ
IAS	Single Pulse Avalanche Current ²	42	A
P_D	Power Dissipation ($T_C=25^\circ C$)	54	W
	Power Dissipation – Derate above 25°C	0.43	W/°C
T_{STG}	Storage Temperature Range	-55 to 150	°C
T_J	Operating Junction Temperature Range	-55 to 150	°C
$R_{\theta JA}$	Thermal Resistance Junction to ambient	62	°C/W
$R_{\theta JC}$	Thermal Resistance Junction to Case	2.3	°C/W

Electrical Characteristics (T_J=25°C, unless otherwise noted)

Symbol	Parameter	Conditions	Min.	Typ.	Max.	Unit
BVDSS	Drain-Source Breakdown Voltage	V _{GS} =0V, I _D =250uA	30	---	---	V
ΔBVDSS/ΔT _J	BV _{DSS} Temperature Coefficient	Reference to 25°C, I _D =1mA	---	0.04	---	V/°C
IDSS	Drain-Source Leakage Current	V _{DS} =30V, V _{GS} =0V, T _J =25°C	---	---	1	uA
		V _{DS} =24V, V _{GS} =0V, T _J =125°C	---	---	10	uA
IGSS	Gate-Source Leakage Current	V _{GS} =±20V, V _{DS} =0V	---	---	±100	nA
RDS(ON)	Static Drain-Source On-Resistance ³	V _{GS} =10V, I _D =20A	---	4.8	6	mΩ
		V _{GS} =4.5V, I _D =10A	---	6.5	9	mΩ
VGS(th)	Gate Threshold Voltage	V _{GS} =V _{DS} , I _D =250uA	1	1.6	2.5	V
ΔV _{GS(th)}	V _{GS(th)} Temperature Coefficient		---	-4	---	mV/°C
gfs	Forward Transconductance	V _{DS} =10V, I _D =10A	---	18	---	S
Q _g	Total Gate Charge ^{3,4}	V _{DS} =15V, V _{GS} =4.5V, I _D =20A	---	11.1	---	nC
Q _{gs}	Gate-Source Charge ^{3,4}		---	1.85	---	
Q _{gd}	Gate-Drain Charge ^{3,4}		---	6.8	---	
Td(on)	Turn-On Delay Time ^{3,4}	V _{DD} =15V, V _{GS} =10V, R _G =3.3Ω I _D =15A	---	7.5	---	ns
T _r	Rise Time ^{3,4}		---	14.5	---	
Td(off)	Turn-Off Delay Time ^{3,4}		---	35.2	---	
T _f	Fall Time ^{3,4}		---	9.6	---	
Ciss	Input Capacitance	V _{DS} =25V, V _{GS} =0V, F=1MHz	---	1160	---	pF
Coss	Output Capacitance	V _{GS} =0V, V _{DS} =0V, F=1MHz	---	200	---	Ω
Crss	Reverse Transfer Capacitance		---	180	---	
R _g	Gate resistance		---	2.5	---	
EAS	Single Pulse Avalanche Energy	V _{DD} =25V, L=0.1mH, I _{AS} =20A	20	---	---	mJ
IS	Continuous Source Current	V _G =V _D =0V, Force Current	---	---	80	A
ISM	Pulsed Source Current ³		---	---	320	A
VSD	Diode Forward Voltage ³	V _{GS} =0V, I _S =1A, T _J =25°C	---	---	1	V
trr	Reverse Recovery Time	V _{GS} =0V, I _S =1A, di/dt=100A/μs T _J =25°C	---	---	---	ns
Q _{rr}	Reverse Recovery Charge		---	---	---	nC

Typical Electrical and Thermal Characteristics

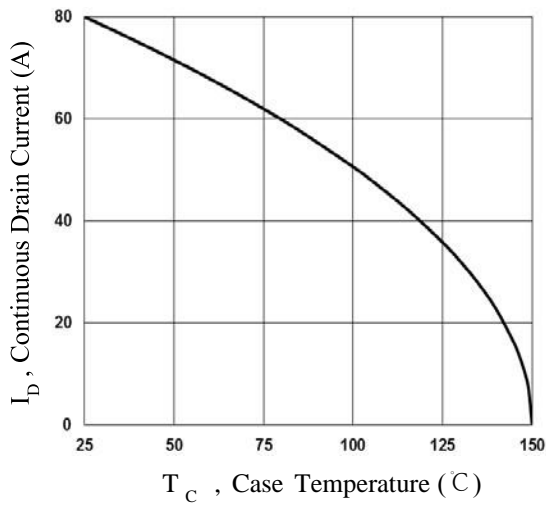

Fig.1 Continuous Drain Current vs. Tc

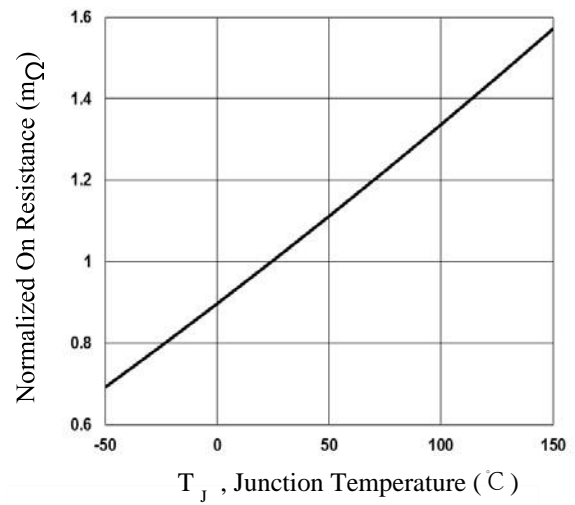

Fig.2 Normalized RDSON vs. Tj

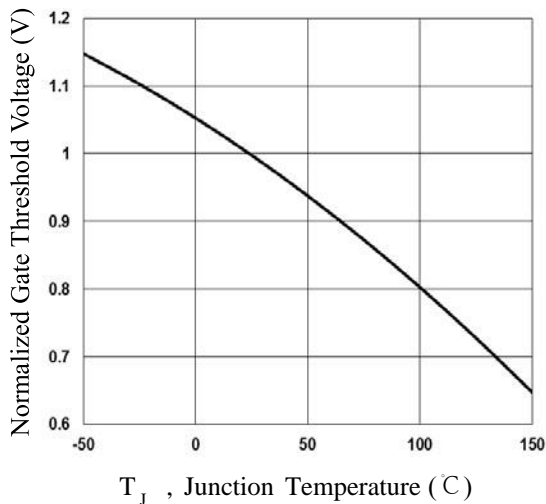

Fig.3 Normalized Vth vs. Tj

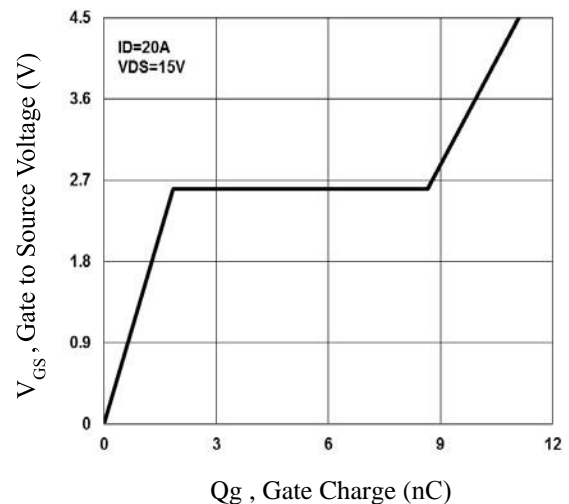

Fig.4 Gate Charge Waveform

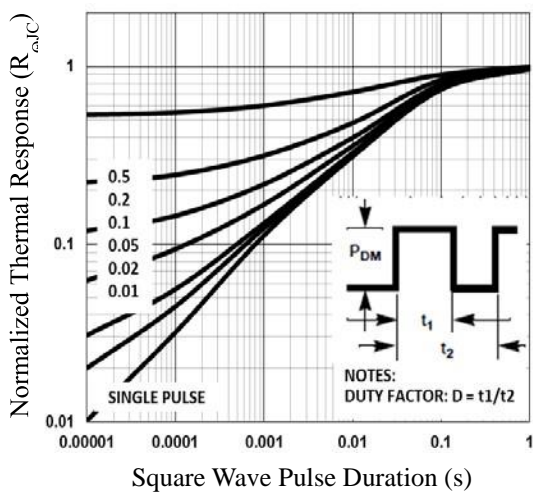

Fig.5 Normalized Transient Impedance

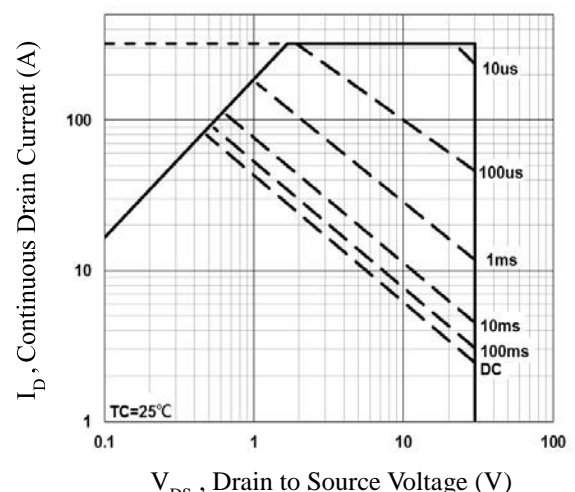

Fig.6 Maximum Safe Operation Area

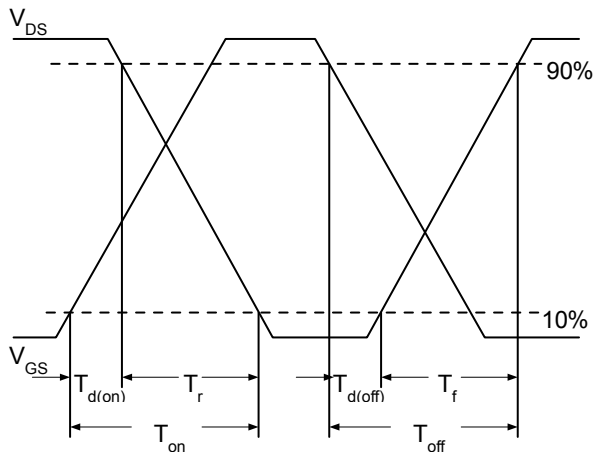

Fig.7 Switching Time Waveform

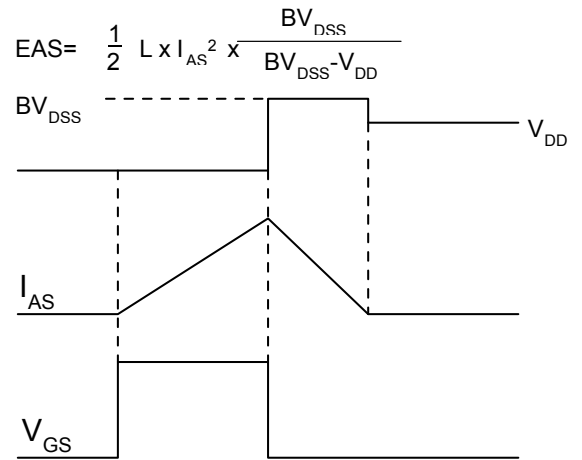
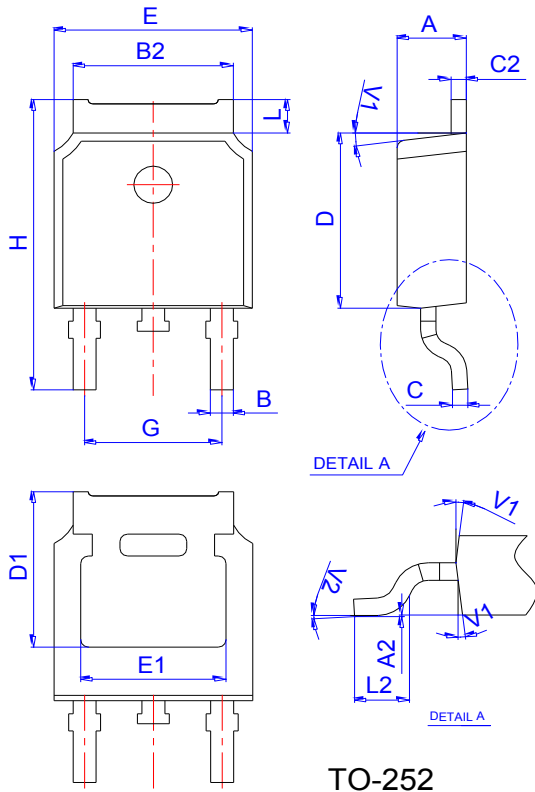

Fig.8 EAS Waveform

Package Mechanical Data



Ref.	Dimensions					
	Millimeters			Inches		
	Min.	Typ.	Max.	Min.	Typ.	Max.
A	2.10		2.50	0.083		0.098
A2	0		0.10	0		0.004
B	0.66		0.86	0.026		0.034
B2	5.18		5.48	0.202		0.216
C	0.40		0.60	0.016		0.024
C2	0.44		0.58	0.017		0.023
D	5.90		6.30	0.232		0.248
D1	5.30REF			0.209REF		
E	6.40		6.80	0.252		0.268
E1	4.63			0.182		
G	4.47		4.67	0.176		0.184
H	9.50		10.70	0.374		0.421
L	1.09		1.21	0.043		0.048
L2	1.35		1.65	0.053		0.065
V1		7°			7°	
V2	0°		6°	0°		6°

Reel Specification-TO-252

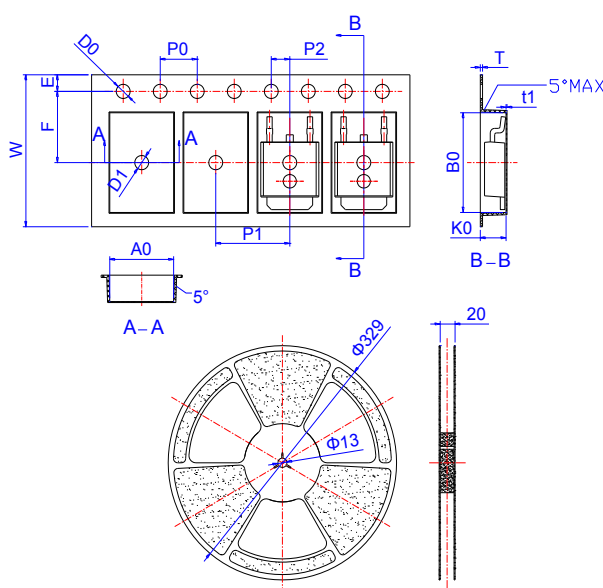

Ref.	Dimensions					
	Millimeters			Inches		
	Min.	Typ.	Max.	Min.	Typ.	Max.
W	15.90	16.00	16.10	0.626	0.630	0.634
E	1.65	1.75	1.85	0.065	0.069	0.073
F	7.40	7.50	7.60	0.291	0.295	0.299
D0	1.40	1.50	1.60	0.055	0.059	0.063
D1	1.40	1.50	1.60	0.055	0.059	0.063
P0	3.90	4.00	4.10	0.154	0.157	0.161
P1	7.90	8.00	8.10	0.311	0.315	0.319
P2	1.90	2.00	2.10	0.075	0.079	0.083
A0	6.85	6.90	7.00	0.270	0.271	0.276
B0	10.45	10.50	10.60	0.411	0.413	0.417
K0	2.68	2.78	2.88	0.105	0.109	0.113
T	0.24		0.27	0.009		0.011
t1	0.10			0.004		
10P0	39.80	40.00	40.20	1.567	1.575	1.583